

Solutions for Your TOUGHEST  
MIXING Applications in

FOOD



## Hydration of Xanthan Gum

# Hydration of Xanthan Gum

Xanthan Gum (E415) is widely used for its thickening and stabilizing effect on emulsions and suspensions.

Xanthan gum forms a gel structure in water which is shear thinning and may be used in combination with other rheology modifiers, particularly Guar gum as the two combine to give greatly increased effects.

## The Process

Xanthan gum can be dispersed into hot or cold liquids, and many grades of gum are available. The powder has a strong tendency to form lumps when added to water and a number of dispersion and hydration methods are used to try to overcome this. These vary according to the scale of production, other ingredients used, etc. but include:

- Slow addition of the powder into the vortex in an agitated vessel. Once dispersed mixing continues to allow the product to hydrate.
- The gum may be premixed with other powdered ingredients such as sugars which reduces the formation of agglomerates by separating the particles.
- Similarly the product may be dispersed into non-aqueous phase liquids such as oils. This is then added to the aqueous phase allowing the gum to hydrate.

## The Problem

Dispersion of gums and thickeners using conventional agitators can give rise to several problems:

- Agglomerates can easily form, even when the above steps are taken to reduce the risk. Agitators do not produce sufficient shear to rapidly break these down.
- Potential full yield is difficult to obtain using traditional methods.
- Many formulations contain unnecessarily high levels of gum to compensate for poor yield, increasing raw material costs.
- Once viscosity increase has started, agitation of the solution and therefore powder dispersion becomes increasingly difficult.
- Long mixing times are required to complete dispersion/hydration. This can degrade the gel.
- Premixing powders or non-aqueous phase liquid with the gum adds to process time and costs.
- Unhydrated gum can gradually hydrate during storage or subsequent processing, leading to undesired changes in product viscosity.
- It is not possible to create high percentage gum solutions with traditional methods. Solutions of this type may be required in certain applications where water is limited in the formulation.

## The Solution

A Silverson High Shear mixer can produce an agglomerate-free dispersion and fully hydrate Xanthan gum in a fraction of the time taken by conventional methods. Where an in-tank mixer is used, a Silverson Ultramix would be most suitable. Operation is as follows:

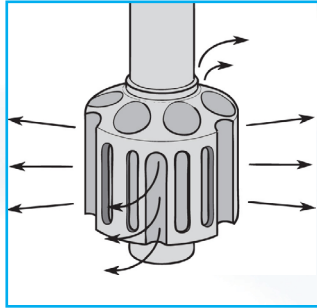

### Stage 1

The vessel is charged with liquid and the mixer is started. The Xanthan gum is added to the water as rapidly as possible. The high speed rotation of the single-piece Ultramix workhead creates a powerful vortex, drawing the powder and liquid down into the workhead.

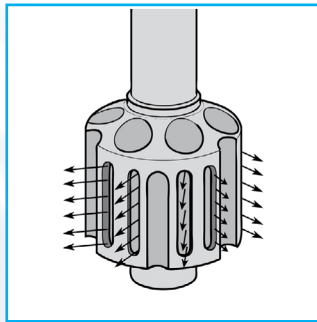

### Stage 2

The materials are then forced through the slots in the side of the workhead and projected back into the body of the mix. Any agglomerates are broken down as they pass through the slots.

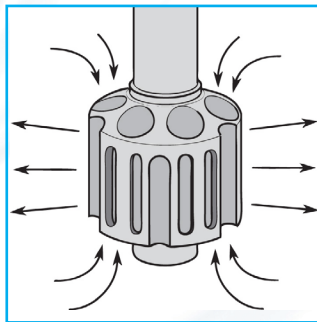

### Stage 3

The vigorous movement in the vessel created by the Ultramix ensures that in a short mixing cycle all the material passes many times through the workhead, progressively reducing the particle size and exposing an increasing surface area to the surrounding liquid. This rapidly completes hydration.

## The Advantages

- Maximized yield/functionality allows products to be formulated with reduced gum content, cutting raw material costs.
- Agglomerate-free mix.
- Operator error is effectively eliminated.
- Rapid mixing times.
- Consistent product quality and repeatability.
- Premixing of gum with powders or non-aqueous phase is not required.

Silverson offers a range of mixers for this application. The batch size, viscosity of the end product, the percentage of Xanthan gum added and the grade of gum used dictates which model would be most suitable - see below.

### Silverson Ultramix

- Ultra Sanitary CIP design
- Excellent in-tank movement
- Capable of rapidly incorporating large volumes of powders
- Ideal for higher viscosity mixes
- Low maintenance

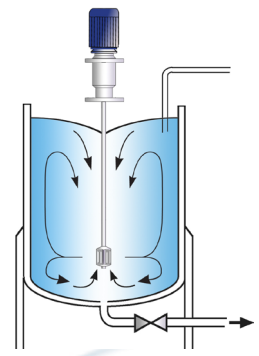

### High Shear Batch Mixers

- Suitable for batches of up to 400 US gallons
- Can be used on mobile floor stands
- Can easily be moved from vessel to vessel

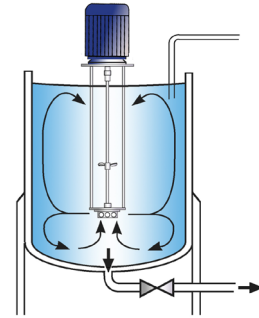

### Silverson Flashmix

- Ideal for larger batches
- Capable of rapidly incorporating large volumes of powder
- Minimized aeration
- Minimized cleaning requirements
- Controlled powder addition rate
- Minimum operator input required
- Suitable for higher viscosities mixes
- Suitable for operation at higher temperatures

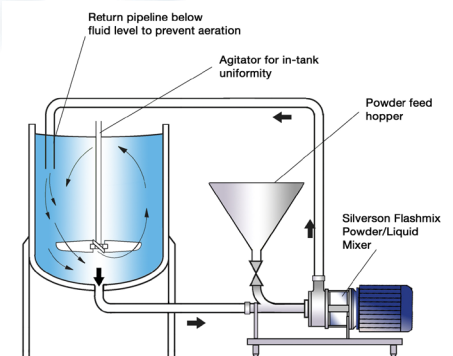

### High Shear In-Line Mixers

- Ideal for larger batches
- Easily retrofitted to existing plant
- Must be used in conjunction with an efficient in-tank agitator to wet out powder
- Aeration free
- Self-pumping
- Can be used to discharge vessel
- Ultra Sanitary models available
- High Viscosity models available

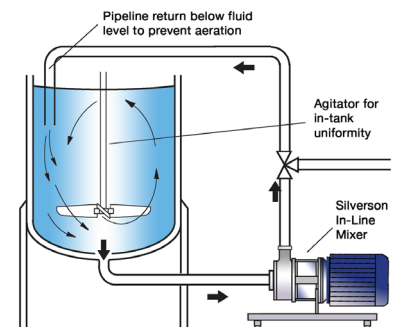

### High Shear Bottom Entry Mixers

- Suitable for use on high viscosity products in conjunction with an anchor stirrer/scrapper
- No immersed shaft - reduces cleaning requirements

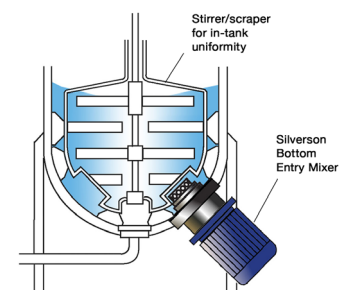

For more information click here to go to [www.silverson.com](http://www.silverson.com)

Silverson Machines, Inc. 355 Chestnut Street, East Longmeadow, MA 01028  
Ph: (413) 525-4825 sales@silverson.com

Information contained in this report is believed to be correct and is included as a guide only. No warranty is expressed or implied as to fitness for use or freedom from patents. Silverson Machines reserve the right to change product specification without notice.

Issue No. 58FA4