

Solutions for Your TOUGHEST
MIXING Applications in

FOOD

Introduction

Preparation of

The Process

Isinglass Finings

The Problem

The Solution

The Advantages



FOOD

Preparation of Isinglass Finings

Lager beer is brewed using “bottom fermenting” yeast which sinks during fermentation. A storage period follows to ensure all the yeast has sunk to the bottom. Demands for a shorter storage period and increased productivity in large-scale breweries has led to the use of finings to accelerate sedimentation.

The use of isinglass finings was originally confined to traditional British and Irish beers, brewed with “top fermenting” yeast which rises during fermentation. Spent yeast and other solids are precipitated by the addition of finings, either in the barrel (with traditional “cask conditioned” beer) or in bulk prior to filtering.

Isinglass is a protein obtained from several varieties of fish.

When added to the beer, the isinglass particles attract the yeast and tannins. The finings sink to the bottom, precipitating the solids to leave the beer clear and bright.

The Process

Isinglass can be supplied in a number of forms:

- Ready-to-use liquid
- Concentrated liquid
- Dried flocculated particles
- Powder
- Freeze-dried powder/granules.

Although liquid forms are easy to use, there are advantages in buying finings in dried form:

- Improved shelf life and temperature tolerance.
- Solutions can be prepared to meet demand.
- Reduced storage requirements.
- Formulation can be adjusted to give optimum results in a particular type of beer.

Solutions are generally prepared separately before addition to the beer. A typical process using a conventional agitator would be as follows:

- The vessel is charged with liquor and the agitator is started.
- Flocked/powdered isinglass is gradually added to the liquor.
- Mixing continues for several hours to ensure hydration is completed.
- Further dilution may be required to give the desired working viscosity.

The Problem

A number of problems can be encountered when using conventional agitators:

- Potential full yield is difficult to obtain using traditional methods.
- Isinglass flakes have a low density and can create a severe dust problem.
- Flocculated product is difficult to wet out, tending to float on the surface of the liquor.
- The vigorous agitation required to incorporate the isinglass can aggravate the dust problem and can cause foaming.
- Partially hydrated isinglass can build up on the vessel wall and parts of the agitator.
- Long periods of soaking are required to complete hydration.

The Solution

Isinglass preparations can be made in a single step without the need for extended soaking by using a Silverson mixer. Operation is as follows:

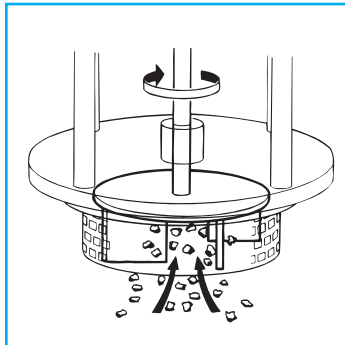

The vessel is charged with the required amount of liquor. The mixer is started and the isinglass is added. The high speed rotation of the rotors creates a powerful suction which draws water and the isinglass particles into the workhead.

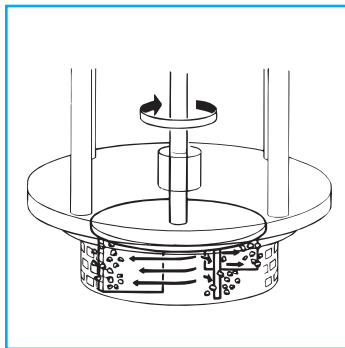

The materials are subjected to intense shear within the workhead. Any agglomerated particles are fully broken down in the clearance between the ends of the rotor blades and the stator wall.

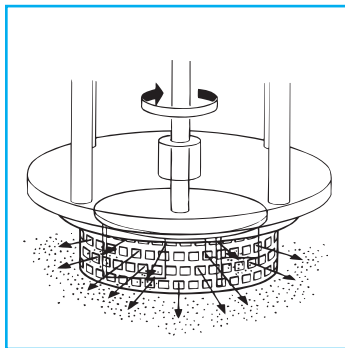

The product is forced out through the stator and projected back into the main body of the mix as fresh material is simultaneously drawn into the workhead.

The entire contents of the vessel pass through the workhead in a short mixing cycle, ensuring hydration is rapidly completed.

The Advantages

This offers a number of advantages over conventional processing methods:

- Significantly better yield than can be obtained by traditional methods.
- Dramatically reduced processing times
- Improved product quality and consistency.
- Stable finished product.
- Improved vessel hygiene.

FOOD

The Advantages

The batch size, formulation, type of ingredients and the viscosity of the end product dictates which machine from the Silverson product line is suited to individual processing requirements.

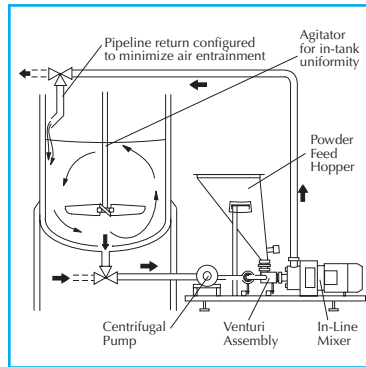

Silverson Flashblend

- Suitable for free-flowing powdered isinglass
- Ideal for larger batches
- Capable of rapidly incorporating large volumes of solids
- Minimized aeration
- Minimum operator input
- Minimized cleaning requirements
- Powder addition rate automatically controlled
- Dust extraction systems available
- Ultra Hygienic models available

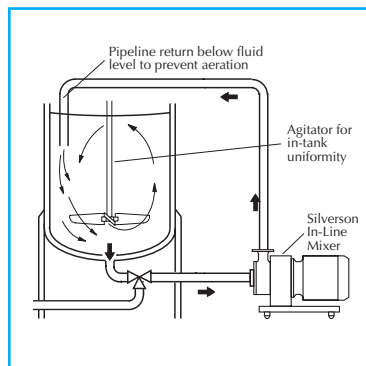

High Shear In-Line Mixers

- Suitable for flocculated and powdered isinglass types.
- Must be used in conjunction with an efficient in-tank agitator to wet out powder as illustrated.
- Ideal for larger batches
- Aeration free
- Easily retro fitted to existing plant
- Self pumping
- Can be used to discharge vessel
- Ultra Hygienic models available

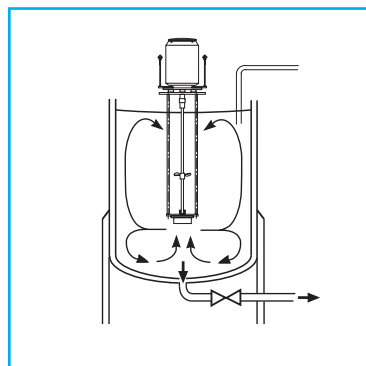

High Shear Batch Mixers

- Suitable for flocculated and powdered isinglass types.
- Suitable for batches of up to 400 gallons
- Can be used on mobile floor stands
- Can easily be moved from vessel to vessel



Silverson Machines, Inc. 355 Chestnut Street, East Longmeadow, MA 01028
Ph: (413) 525-4825 • Fax:(413) 525-5804 • www.silverson.com

Issue No. I2FA2

Information contained in this report is believed to be correct and is included as a guide only. No warranty is expressed or implied as to fitness for use or freedom from patents. Silverson Machines reserve the right to change product specification without notice.