

BT-Online Series

Real-time Insights for Smart Processes

PARTICLE SIZE



BT-Online1 (Dry)

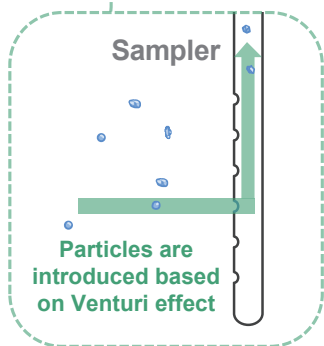
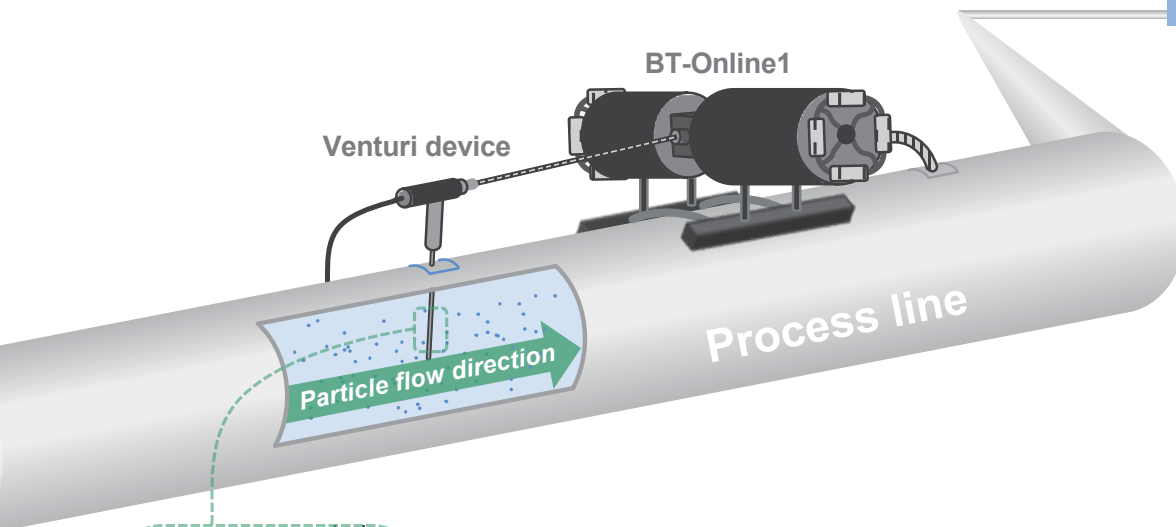
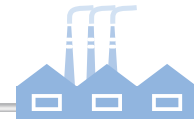

Online measurement for dry powder

The BT-Online1 is used as an online particle size analyzer for dry particles within the size range of 0.1 to 1000 μm . The BT-Online1 is integrated into a process loop, providing real-time measurement results that assist in quality inspection and parameter monitoring.

Representative sampling

Two samplers are available for the BT-Online1

Straight flute

- Suitable for the sample with wide particle size distribution
- Good representative
- Simple maintenance

Sample auger

- Suitable for thin material flow
- Threaded rod ensures effective extraction

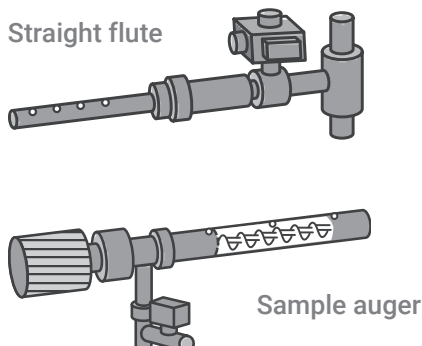

Dual protection from contamination

The lenses of the BT-Online1 are protected using a dual air curtain and sheath gas, which greatly reduce maintenance costs, increase efficiency, and prevent costly downtime.

Dual air curtain

- Protection of lenses from contamination based on the two generated positive pressure zones
- Assistance in sample dispersion

Sheath gas

- Hydrodynamic focusing of the sample jet ensures the correct flowing path for the particles
- Protection of lenses from pollution using an annular curtain

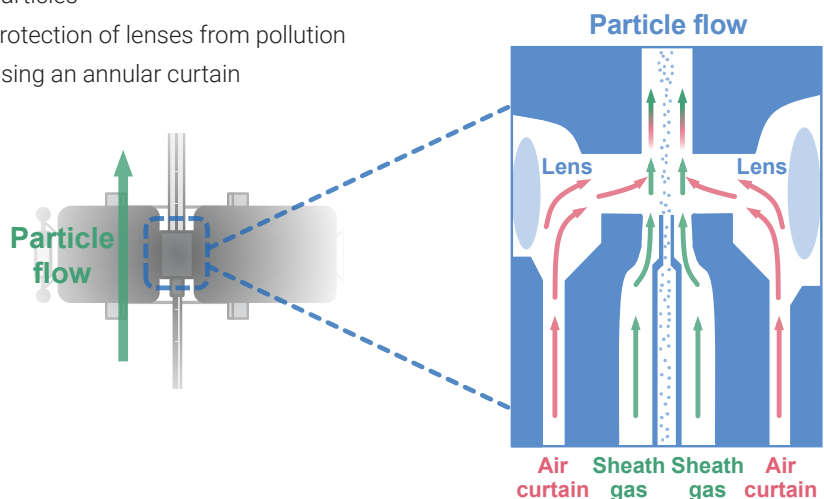

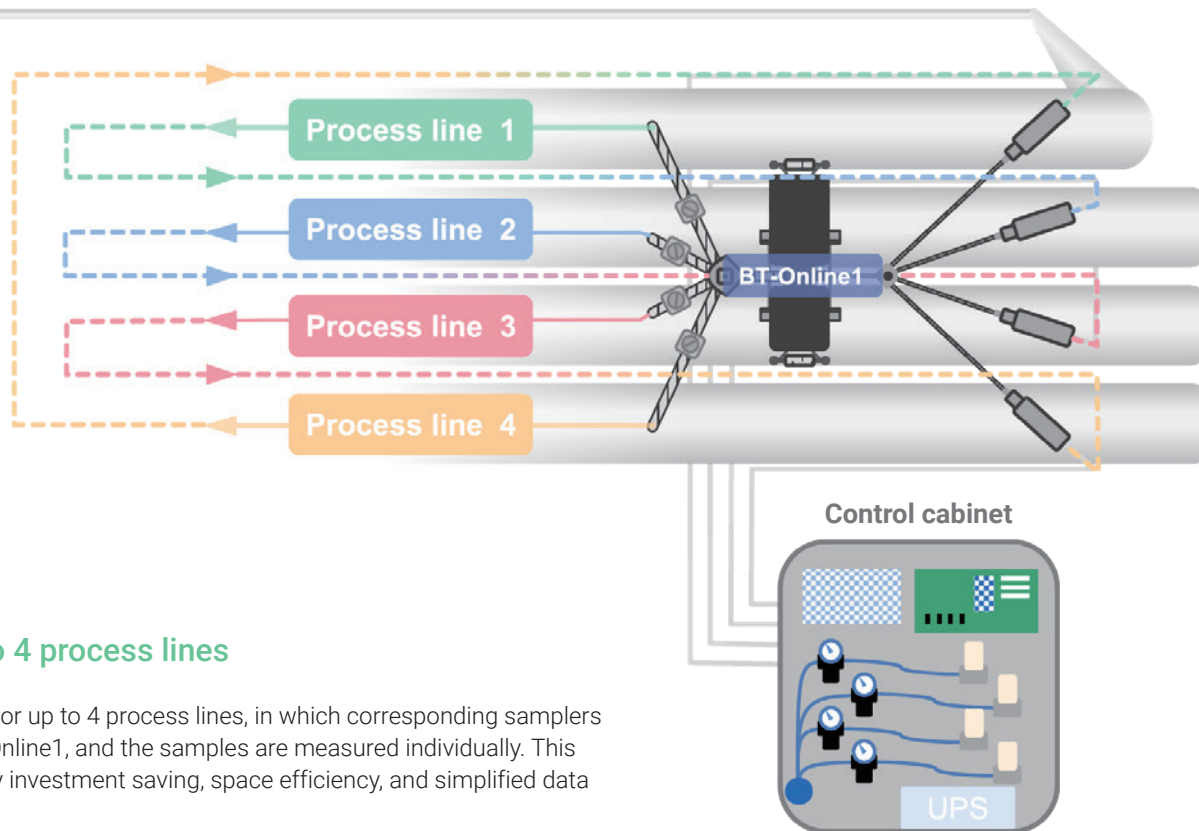

Monitoring of up to 4 process lines

The BT-Online1 can monitor up to 4 process lines, in which corresponding samplers are connected to the BT-Online1, and the samples are measured individually. This design is characterized by investment saving, space efficiency, and simplified data management.

Automatic alignment

Automatic alignment will be carried out, ensuring accuracy for every measurement in case of harsh working environment.

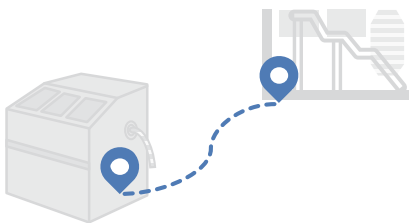
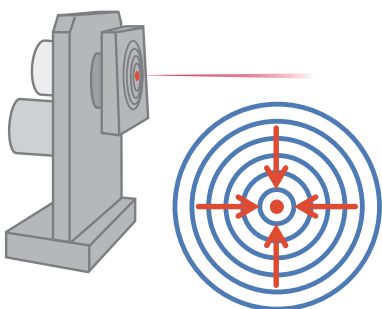

Intuitive software

Individual SOP for each process line can be configured, and monitoring curves are intuitively displayed in the software.

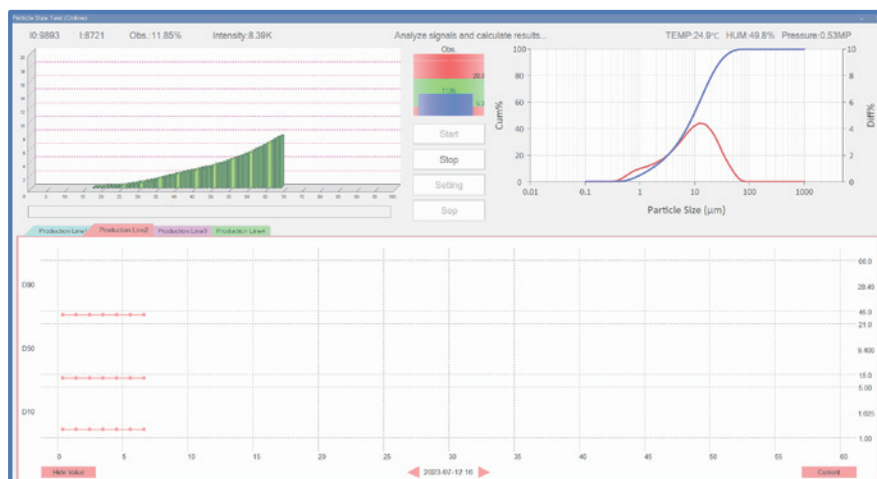

Multiple communication protocols

The BT-Online1 can cooperate with the DCS or PLC system of the plant. Available communication protocols are **TCP**, **Modbus RTU**, and **4 - 20 mA**.

BT-Online1 (Dry)

Application of the BT-Online1

Cements



Minerals



Chemicals



Agrochemicals



Pharmaceuticals



Battery materials



Metal powders



Ceramics



01 Measurement of cement powder in air gravity conveyor

By changing the rotation speed of the classifier, the particle sizes of the cement particles measured with the BT-Online1 vary.

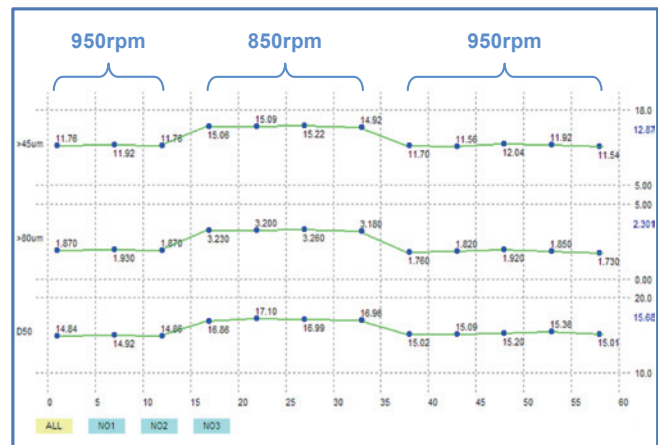
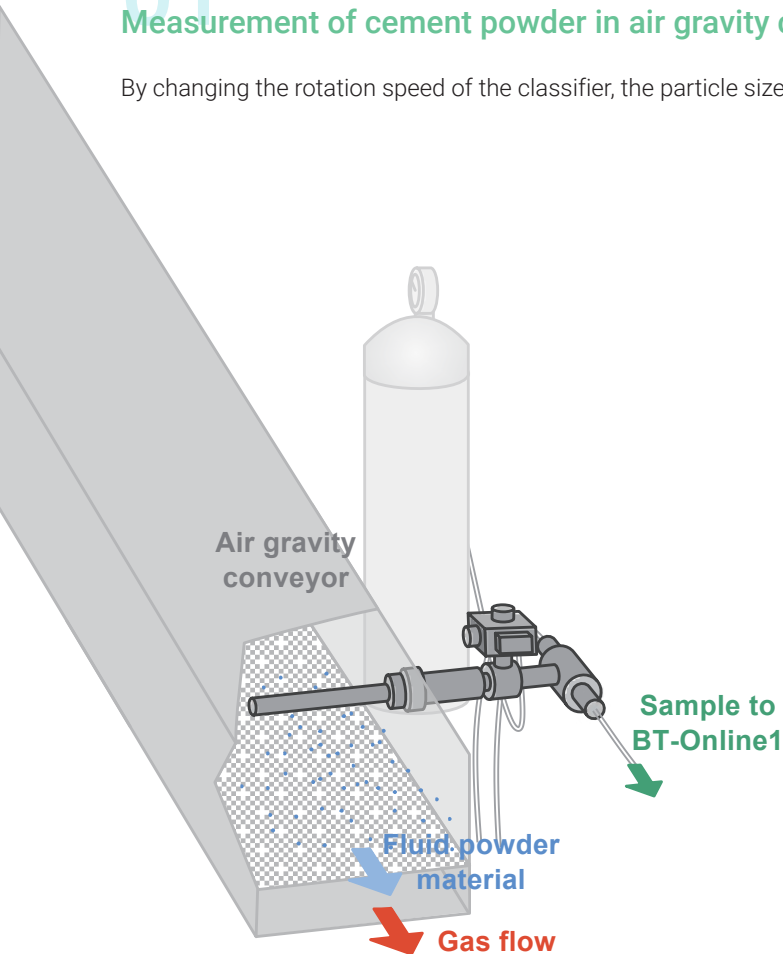

02

Various application of the BT-Online1 in a cement plant

A general portland cement production line is demonstrated below. The BT-Online1 can be applied in different positions for different purposes. Examples are shown below:

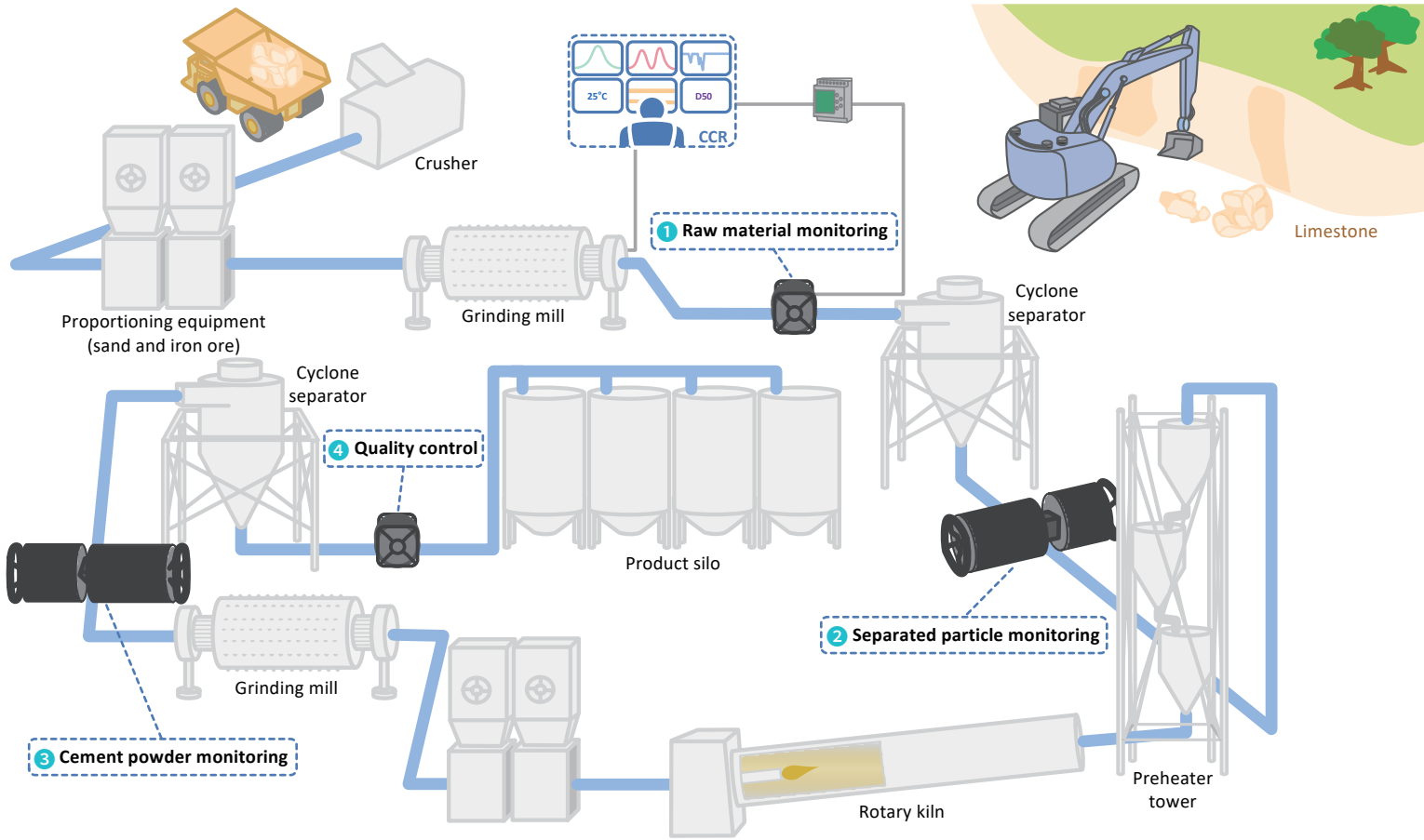

03

Further applications of the BT-Online1

Graphite powder



Fodder



Silicone powder



BT-Online2 (Wet)

Innovative solution for online measurement using wet method

The BT-Online2 applies patented Fourier and Inverse Fourier Optical System, providing reliable measurement results with the same accuracy level as that of the laboratory instrument. A total of 92 detectors are precisely arranged in the optical setup that is responsible for accurate particle size analysis ranging from 0.02 to 2000 μm .



Patented optical setup promotes measurement accuracy

The patented Fourier and Inverse Fourier Optical System provided by Bettersize Instruments contains forward, lateral, and backward detectors, realizing the detection of scattered light signals in a very wide angular range.

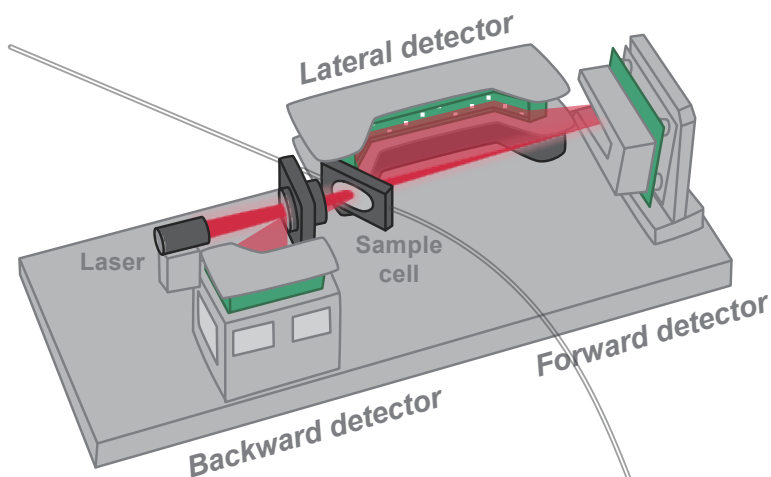

Benefits of the optical setup:

- Tilted sample cell alleviates total internal reflection.
- Expands measurement range
- Improves the measurement accuracy for small particles.

Reliable pneumatic sampling system

This design allows:

- Effective sample extraction without cross-contamination
- Good operation safety without using electricity

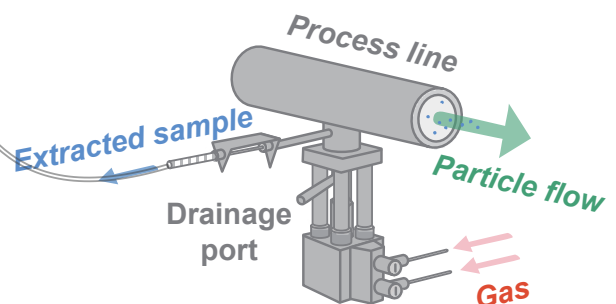

Achieving optimal obscuration through external dilution

In most instances, the solid contents of the samples are quite high, resulting in high obscuration when samples are introduced to the BT-Online2. Hence, an external dilution system is necessary for primary dilution.



External dilution system of the BT-Online2

Align with laboratory instrument

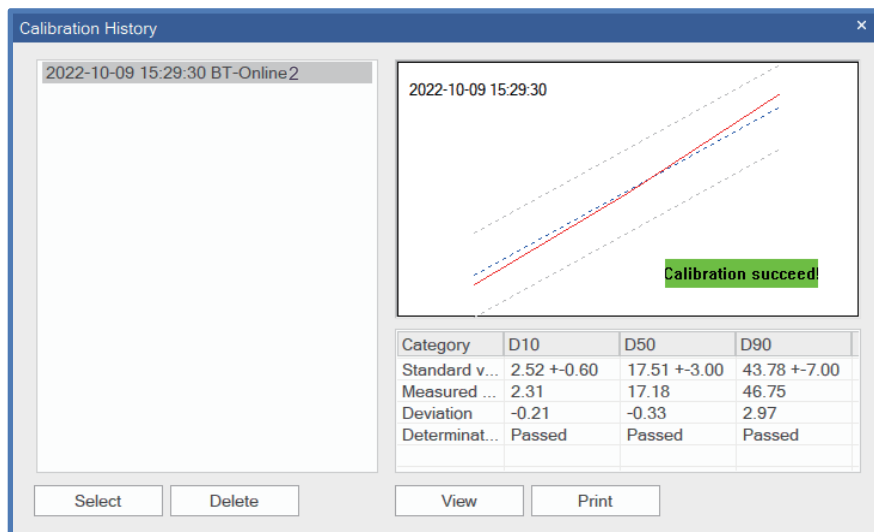

By performance verification, the measured value provided by the BT-Online2 is consistent with the nominal value of the working reference standard.

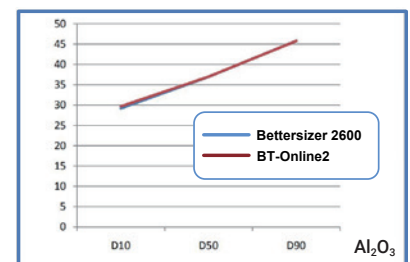
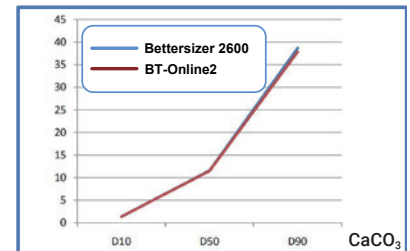

The result deviations between the BT-Online2 and the lab instrument are quite small – the particle size curves almost overlap each other.

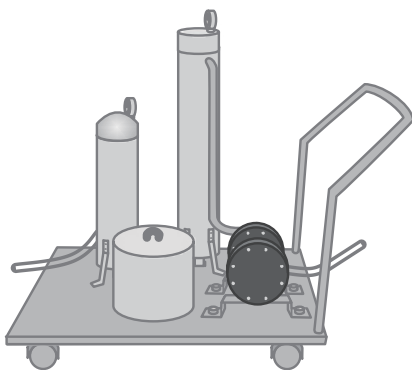

Filtration system enables recycling of organic solvent

When organic solvent is applied as a carrier instead of water, a movable filtration system is available that works hand in glove with the BT-Online2 for recycling the organic solvent, which saves your investment.

Monitoring of up to 4 process lines

Up to 4 process lines can be attached to the BT-Online2 with individual SOPs. The measurement result for each process line is intuitively displayed in the software, which saves equipment investment and simplifies data management.

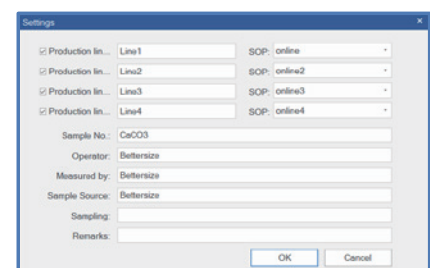

BT-Online2 (Wet)

Application of the BT-Online2

Metal powders



Ceramics



Chemicals



Agrochemicals



Pharmaceuticals



Battery materials



Ink



Abrasives



01

Continuous and accurate measurement in various industries

A patented optical system offers accurate measurement results with outstanding reproducibility.

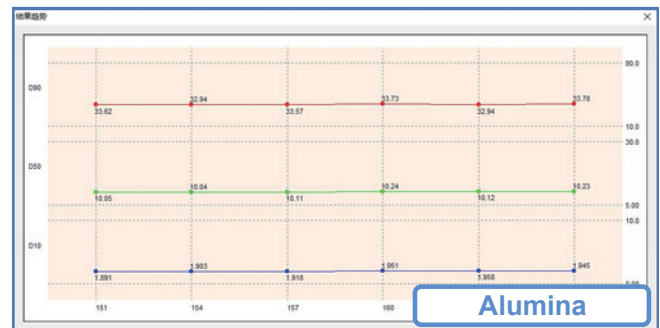
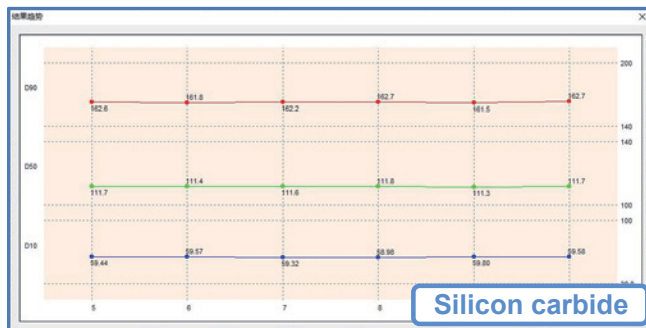

02

Measurement procedure of the BT-Online2 with an external dilution system

As an accessory, an external dilution system can be connected to the BT-Online2, offering a solution for measuring concentrated samples in case of multiple scattering. The external dilution system has 4 inlet ports that correspond to 4 process lines and 1 outlet port for delivering the primary diluted sample.

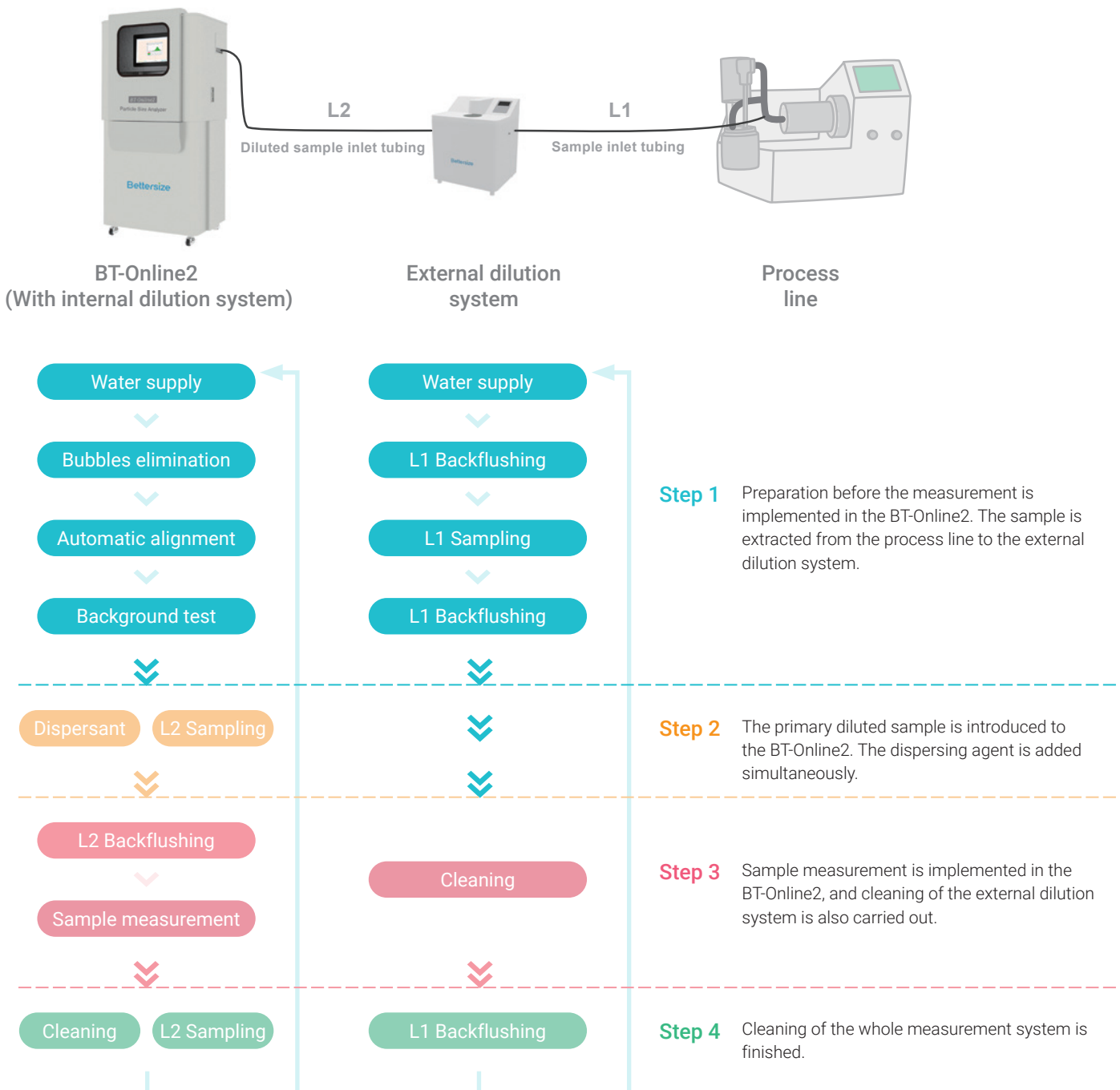
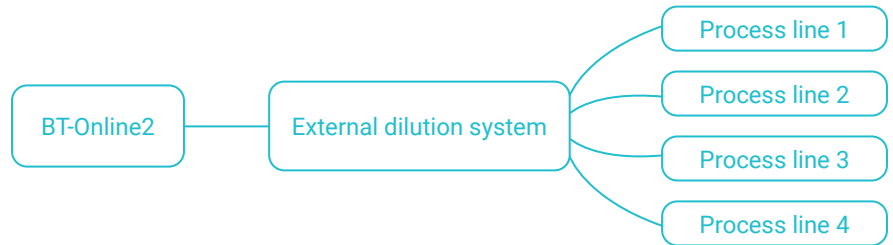









Specifications

BT-Online1	
Parameters	Values
Measurement range	0.1 - 1000 μm
Measurement principle	Mie scattering theory and Fraunhofer diffraction theory
Accuracy	$\leq 1\%$ (D50 of certified reference material)
Lens protection	Dual air curtain
Pressure of carrier gas	0.4 - 0.8 MPa
Airflow volume	≥ 1000 L/min
Laser power	Semiconductor laser
Number of detector	68
Carrier gas	Compressed air/inert gas
Communication protocol	TCP, Modbus RTU, 4 - 20 mA
Protection	IP65
Sample required per measurement	2 - 20 g
Power	AC220 V, 50 / 60 Hz, 90 W
Dimension	800 (L) x 280 (W) x 280 (H) mm (Main unit)
Weight	21 kg (Main unit)

BT-Online2	
Parameters	Values
Measurement range	0.02 - 2000 μm
Measurement principle	Mie scattering theory and Fraunhofer diffraction theory
Accuracy	$\leq 0.5\%$ (D50 of certified reference material)
Sampling method	Peristaltic pump
Measurement interval	≥ 1 s
Laser power	Fiber laser
Number of detector	92
Ultrasonication	50 W
Communication protocol	TCP, Modbus RTU, 4 - 20 mA
Power	AC220 V, 50 / 60 Hz, 200 W
Dimension	782 (L) x 530 (W) x 1592 (H) mm
Weight	85 kg

About Betersize

<p>No.1</p> <p>Market Share in China</p> 	<p>106</p> <p>Patents</p> 	<p>43</p> <p>Global Labs</p> 	<p>22k+</p> <p>Organizations Using Betersize's Technology</p> 
<p>30</p> <p>Years in Business</p> 	<p>15%</p> <p>Revenue Invested in R&D</p> 	<p>92</p> <p>Countries Covered</p> 	<p>95%</p> <p>In-house Production for Strict Quality Control</p> 

Compliance

All series of Betersize instruments are in compliance with **ISO9001** and **CE certification**. The software complies with **U.S. FDA 21 CFR Part 11**, ensuring the validity and reliability of measurement results and meeting traceability requirements.

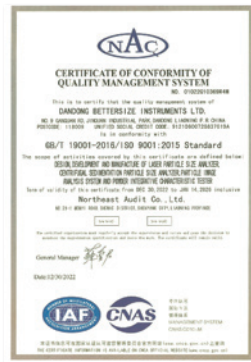

Certified Service and Support

We provide exceptional customer care throughout your product's lifecycle, including:

- **3-Year Warranty** for reliable performance.
- **Expert Support:** Installations, training, workshops, and troubleshooting.
- **Maintenance & Upgrades:** Preventive care, hardware and software updates, and repair services.
- **24/7 Emergency Service** for critical assistance.



Discover more: betersizeinstruments.com/services 

Bettersize

BETTER PARTICLE SIZE SOLUTIONS

Bettersize Instruments Ltd.

No. 9, Ganquan Road, Jinqun Industrial Park,
Dandong, Liaoning, China

Postcode: 118009

Tel: +86-755-26926582

Bettersize Inc.

3188 Airway Ave, Suite K-2, Costa Mesa,
CA 92626, United States

Tel: +1 833-699-7493 (SIZE)

info@bettersize.com

www.bettersizeinstruments.com



BT-Online1



BT-Online2



Official Youtube

Disclaimer: By using or accessing any materials provided by Bettersize Instruments Ltd. in electronic format, you agree to the Disclaimer without any qualification or limitation. While diligent care has been taken to ensure the accuracy of the information contained herein, Bettersize Instruments Ltd. shall not be liable for any errors or damages in connection with the use of these materials. The information is provided as general information, and no representation or warranty, whether express or implied, is made as to its accuracy, completeness, or correctness. It does not constitute part of a legal offer or contract. Bettersize Instruments Ltd. reserves the right to modify, alter, add, and delete the content outlined in these materials without prior notice and without any subsequent liability to the company.

Copyright: © 2025 Bettersize Instruments Ltd. | All Rights Reserved
13.0008.00.02