



Microfluidics™

Superior Knowledge | Superior Results



M110P Microfluidizer™ Pharma Basic Processor

M110P Microfluidizer™ Pharma Basic Processor

Microfluidizer™ Bench-Top Processor Model Is Recommended For:

- ◆ Production of stable nano-dispersions and nano-emulsions
- ◆ Cell disruption (yeast, E.coli, etc.)
- ◆ Microencapsulation in polymers, liposomes and oils
- ◆ Deagglomeration

The M110P models have been designed to reliably achieve continuous operating pressures up to 30,000 psi.

Microfluidizer™ processors maximize the energy-per-unit fluid volume, resulting in uniform submicron particles.



Options

- ◆ Larger capacity glass or stainless steel reservoirs
- ◆ Seal quench system
- ◆ Additional interaction chamber
- ◆ Additional Auxiliary Processing Module (APM)
- ◆ IQOQ on-site execution
- ◆ FAT, SAT, on-site startup and operator training
- ◆ Preventative maintenance service
- ◆ Extended warranty



M110P “Plug and Play” Laboratory Model for Continuous High Shear Processing

- ◆ Achieve processing pressures up to 2068 bar (30,000 psi)
- ◆ Produces product flow rate up to 120 ml/min (100 ml/min on 50 Hz model)
- ◆ ASME-BPE compliant
- ◆ cGMP ready
- ◆ Tube-in-tube pharmaceutical grade heat exchanger
- ◆ 7” HMI color touch screen control
- ◆ Inlet and outlet thermocouples with display on touch screen
- ◆ Pressure transducer with display on touch screen
- ◆ Highest shear rates on the market
- ◆ Guaranteed scalability
- ◆ Customizable options to suit every application
- ◆ CE compliant

Utilizing Microfluidics’ fixed-geometry interaction chamber technology, and a ceramic (zirconia) plunger, the M110P Microfluidizer processor is capable of processing a wide variety of applications such as emulsions, suspensions, and cell disruption, including the most difficult yeast and plant cells, in as few as 1-2 passes. What’s more, the process is repeatable and is guaranteed to scale up to pilot and/or production volumes.



M110P Microfluidizer™ Pharma Basic Processor

The M110P family of machines contains an on-board 1.5KW (2HP) electric-hydraulic drive that powers a single acting intensifier pump. Process pressures may be adjusted from 138-2068 bar (2,000-30,000 psi) on the M110P to produce the desired product results.

As the reciprocating intensifier pump travels through its pressure stroke, it drives the product at constant pressure through the interaction chamber. Within the chambers are unique fixed-geometry micro-channels through which the product stream will accelerate to high velocities. This creates high-shear and impact forces to bring about the desired results as the high velocity product stream impinges on itself and/or on wear-resistant surfaces.

Upon exiting the interaction chamber, the product flows either through an external cooling coil or heat exchanger, which precisely regulates the product to a desired temperature. At this point the product may be recirculated through the system for further processing or sent to the next step in the process.

Specifications

Description	M110P
Pressure Range	138 – 2068 bar (2,000 – 30,000 psi)
Minimum Sample Size	50 mL
Flow Rate* Approximately (With Water)	Up To 120 ml/min - 60 Hz Up To 100 ml/min - 50 Hz
Product Temperature Limit	73°C (165°F)
Power Requirements	60 Hz/120 VAC/20 Amp 60 Hz/230 VAC/10 Amp 50 Hz/220 VAC/12 Amp
Dimensions W x D x H	102cm x 69cm x 58cm (40" x 27" x 23")
Weight	136 kg (300 lbs)

Standard Features

Interaction Chamber Material	Diamond
Plunger Material	Zirconia Ceramic
Enclosure	Stainless Steel
Drive Method	Electric/Hydraulic
Auxiliary Processing Module	Ceramic
300 ml Glass Feed Reservoir	Yes
Stainless Steel Feed Reservoirs	Optional
Cooling Coil Assembly	Yes

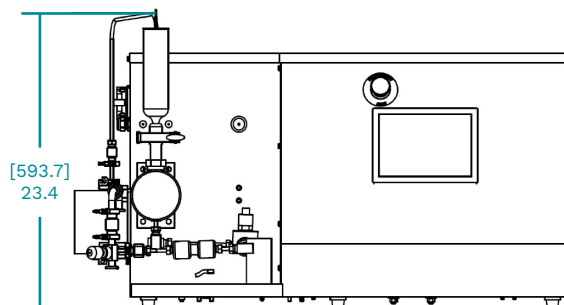
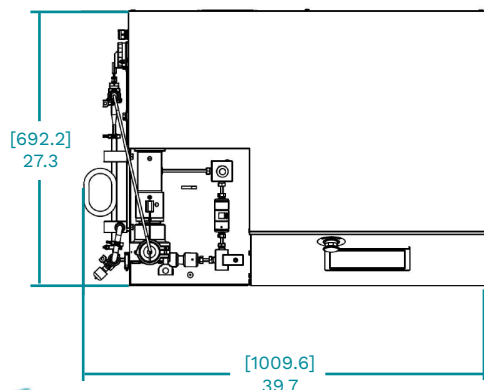



Microfluidics International Corporation
90 Glacier Drive, Suite 1000,
Westwood, MA 02090, USA

Tel: 617-969-5452 • 800-370-5452
Fax: 617-965-1213

Email: mixinginfo@idexcorp.com
Web: www.microfluidics-mpt.com

Industry Leading Insights & News:
<https://www.microfluidics-mpt.com/blog>



Material Processing Technologies